

200605110005

PART OF THE NORTHWEST QUARTER OF SECTION 23, TOWNSHIP 18 NORTH, RANGE 18 EAST, W.M.



LEGEND

- SET 5/8" REBAR W/ YELLOW CAP - "CRUSE 36815"
- FOUND PIN & CAP
- x — FENCE

GRAPHIC SCALE

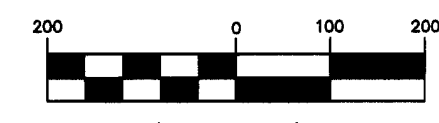

(IN FEET)
1 inch = 200 ft.

SEE SHEET 2 OF LINE TABLE

FD PIN & CAP
LS 9606
VISITED 9/05

FD PIN & CAP
LS 9606
VISITED 9/05

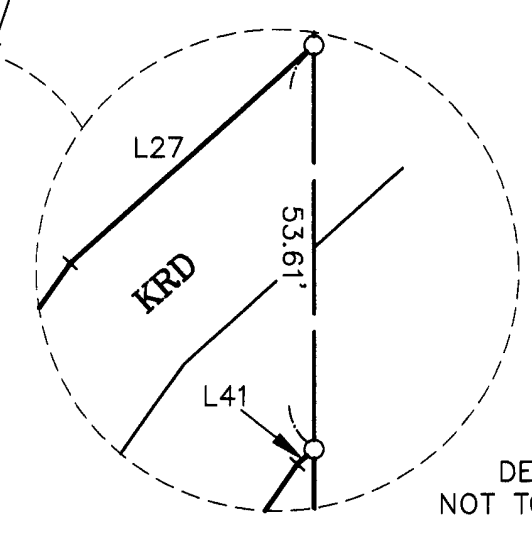
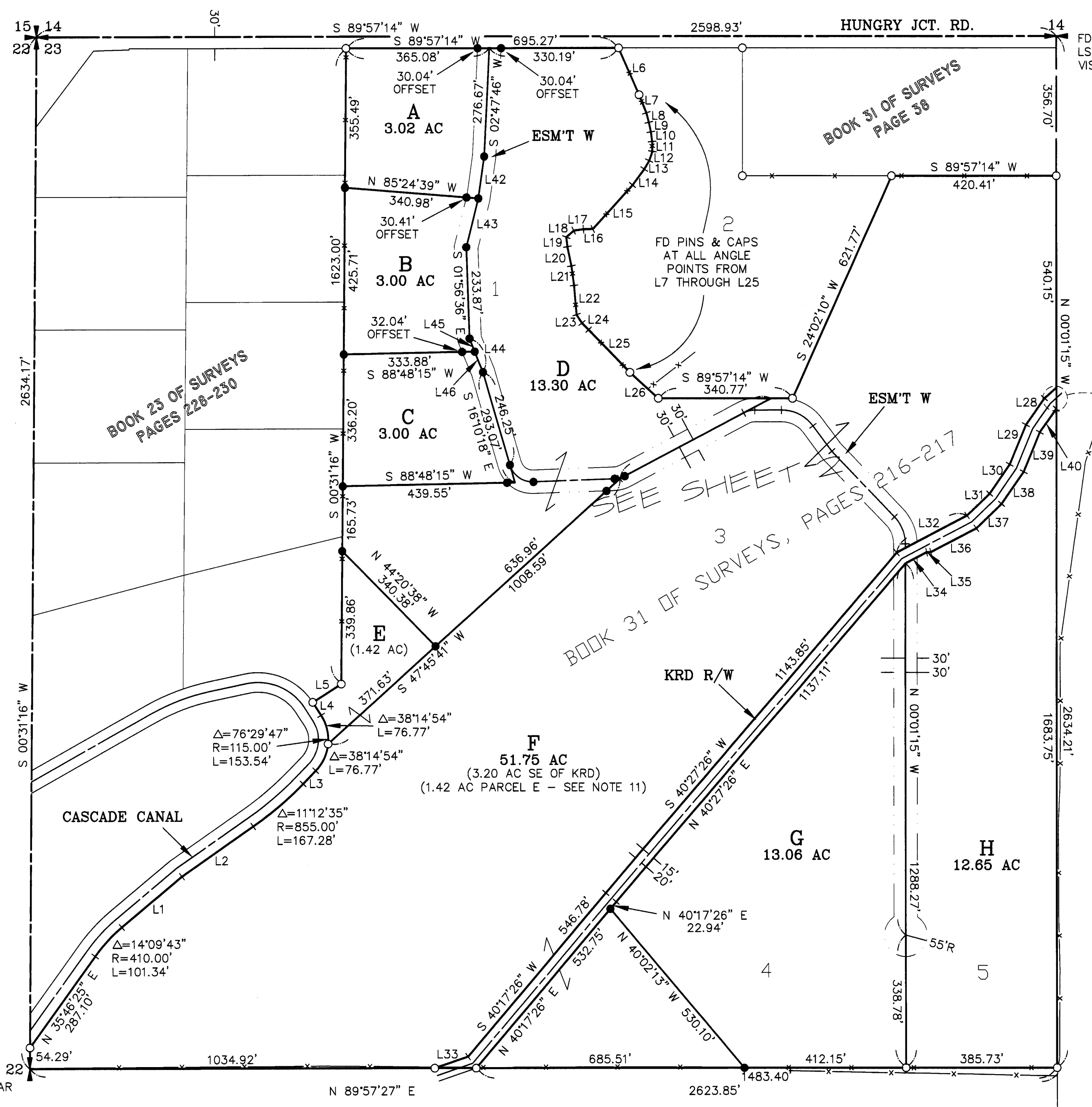

DETAIL
NOT TO SCALE

AUDITOR'S CERTIFICATE

Filed for record this 11TH day of MAY,
2006, at 12:24 P.M., in Book 32 of Surveys at
page(s) 158 at the request of Cruse & Associates.

JERALD V. PETTIT BY: *J. Pettit*
KITTITAS COUNTY AUDITOR

SURVEYOR'S CERTIFICATE

This map correctly represents a survey made by
me or under my direction in conformance with
the requirements of the Survey Recording Act
at the request of DCCDLC LLC in APRIL of 2006.

Chris Cruse
CHRISTOPHER C. CRUSE
Professional Land Surveyor
License No. 36815

MAY 11, 2006
DATE

EXPIRES: 1/10/07

X	X	
X	X	

CRUSE & ASSOCIATES
PROFESSIONAL LAND SURVEYORS
217 East Fourth Street P.O. Box 959
Ellensburg, WA 98926 (509) 962-8242

DCCDLC LLC PROPERTY

FD 5/8" REBAR
VISITED 9/05

200605110005

PART OF THE NORTHWEST QUARTER OF SECTION 23,
TOWNSHIP 18 NORTH, RANGE 18 EAST, W.M.



LEGEND

- SET 5/8" REBAR W/ YELLOW CAP - "CRUSE 36815"
- FOUND PIN & CAP
- x — FENCE

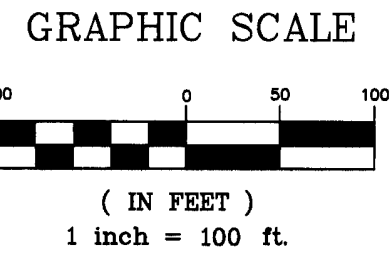

LINE	DIRECTION	DISTANCE
L1	N 49°56'08" E	200.62'
L2	N 55°05'43" E	222.62'
L3	N 43°53'08" E	46.65'
L4	N 32°36'40" W	39.63'
L5	N 57°23'20" E	86.73'
L6	S 23°28'51" E	130.26'
L7	S 21°49'51" E	49.77'
L8	S 14°46'18" E	25.22'
L9	S 11°35'16" E	24.98'
L10	S 07°43'20" E	24.84'
L11	S 01°14'15" E	24.88'
L12	S 18°47'15" W	25.07'
L13	S 29°16'03" W	25.24'
L14	S 36°40'23" W	50.09'
L15	S 42°08'06" W	150.88'
L16	S 88°49'35" W	24.00'
L17	S 81°59'28" W	25.26'
L18	S 48°37'53" W	25.35'
L19	S 06°19'52" E	24.81'
L20	S 11°31'19" E	50.13'
L21	S 07°49'34" E	50.23'
L22	S 04°51'00" E	75.00'
L23	S 32°22'56" E	25.45'
L24	S 45°04'59" E	24.09'
L25	S 44°02'37" E	151.16'
L26	S 47°35'51" E	98.20'
L27	S 48°14'26" W	41.21'
L28	S 34°57'26" W	82.57'
L29	S 22°10'26" W	109.06'
L30	S 34°36'26" W	90.83'
L31	S 46°00'26" W	80.18'
L32	S 62°05'26" W	203.00'
L33	S 70°45'26" W	89.64'
L34	N 62°05'26" E	61.67'
L35	N 89°57'21" E	10.70'
L36	N 62°05'26" E	130.83'
L37	N 46°00'26" E	89.82'
L38	N 34°36'26" E	99.17'
L39	N 22°10'26" E	108.94'
L40	N 34°57'26" E	73.43'
L41	N 48°14'26" E	0.86'
L42	S 07°57'43" W	107.75'
L43	S 14°02'56" W	128.33'
L44	S 21°46'02" E	92.30'
L45	S 21°46'02" E	35.77'
L46	S 21°46'02" E	56.54'

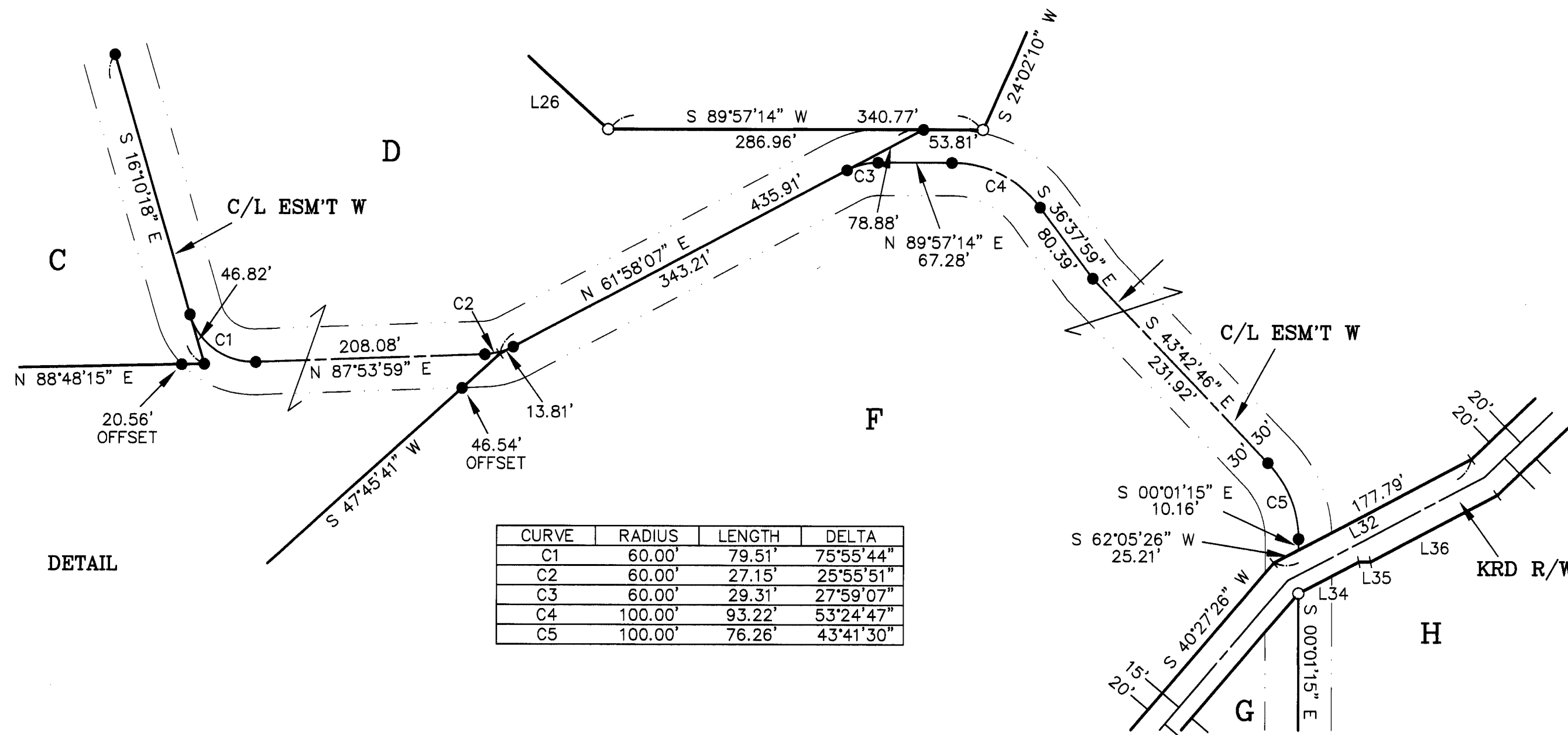

CURVE	RADIUS	LENGTH	DELTA
C1	60.00'	79.51'	75°55'44"
C2	60.00'	27.15'	25°55'51"
C3	60.00'	29.31'	27°59'07"
C4	100.00'	93.22'	53°24'47"
C5	100.00'	76.26'	43°41'30"

AUDITOR'S CERTIFICATE

Filed for record this 11TH day of MAY,
2006, at 12:24 P.M., in Book 32 of Surveys at
page(s) 159 at the request of Cruse & Associates.

JERALD V. PETTIT BY: *S. Niggelbohn*
KITITAS COUNTY AUDITOR

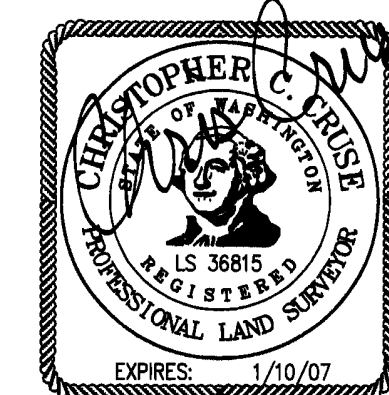

MAY 11, 2006

CRUSE & ASSOCIATES
PROFESSIONAL LAND SURVEYORS
217 East Fourth Street P.O. Box 959
Ellensburg, WA 98926 (509) 962-8242
DCCDLC LLC PROPERTY

PART OF THE NORTHWEST QUARTER OF SECTION 23, TOWNSHIP 18 NORTH, RANGE 18 EAST, W.M.

NOTES:

1. THIS SURVEY WAS PERFORMED USING A NIKON DTM-521 TOTAL STATION. THE CONTROLLING MONUMENTS AND PROPERTY CORNERS SHOWN HEREON WERE LOCATED, STAKED AND CHECKED FROM A CLOSED FIELD TRAVERSE IN EXCESS OF 1:10,000 LINEAR CLOSURE AFTER AZIMUTH ADJUSTMENT.
2. THIS SURVEY MAY NOT SHOW ALL EASEMENTS OR IMPROVEMENTS WHICH MAY PERTAIN TO THIS PROPERTY.
3. ACCORDING TO KITTITAS RECLAMATION DISTRICT (KRD) RECORDS, PARCEL A HAS 1 IRRIGABLE ACRES; PARCEL B HAS 2 IRRIGABLE ACRES; PARCEL C HAS 3 IRRIGABLE ACRES; PARCEL D HAS 9 IRRIGABLE ACRES; PARCEL E HAS 1 IRRIGABLE ACRES; PARCEL F HAS 29 IRRIGABLE ACRES; PARCEL G HAS 10 IRRIGABLE ACRES; PARCEL H HAS 12 IRRIGABLE ACRES. KRD WATER MAP ONLY BE APPLIED TO IRRIGABLE ACREAGE.
4. FULL PAYMENT OF ANNUAL KRD ASSESSMENT IS REQUIRED REGARDLESS OF THE USE OR NON-USE OF WATER BY THE OWNER.
5. THE LANDOWNERS MUST PROVIDE FOR THE APPOINTMENT OF ONE WATER MASTER FOR EACH TURNOUT, WHO SHALL BE RESPONSIBLE FOR ORDERING WATER FOR THE ENTIRE PROPERTY. THE WATER MASTER WILL BE RESPONSIBLE FOR KEEPING WATER USE RECORDS FOR EACH LOT. KRD WILL ONLY BE RESPONSIBLE FOR KEEPING RECORDS ON THE TOTAL WATER ORDERED AT THE KRD TURNOUT.
6. KRD OPERATIONS AND MAINTENANCE ROADS ARE FOR DISTRICT USE ONLY. RESIDENTIAL AND RECREATIONAL USE IS PROHIBITED.
7. KRD IS ONLY RESPONSIBLE FOR DELIVERY OF WATER TO THE HIGHEST FEASIBLE POINT IN EACH 160 ACRE UNIT OR DESIGNATED TURNOUT. THE KRD IS NOT RESPONSIBLE FOR WATER DELIVERY LOSS (SEEPAGE, EVAPORATION, ETC.) BELOW THE DESIGNATED TURNOUT.
8. AN IRRIGATION EASEMENT 10 FEET IN WIDTH IS RESERVED ALONG ALL LOT LINES. THE 10 FOOT EASEMENT SHALL ABUT THE EXTERIOR PROPERTY BOUNDARY AND SHALL BE DIVIDED 5 FEET ON EACH SIDE OF INTERIOR LOT LINES.
9. KITTITAS COUNTY WILL NOT ACCEPT PRIVATE ROADS FOR MAINTENANCE AS PUBLIC STREETS OR ROADS UNTIL SUCH STREETS OR ROADS ARE BROUGHT INTO CONFORMANCE WITH CURRENT COUNTY ROAD STANDARDS. THIS REQUIREMENT WILL INCLUDE THE HARD SURFACE PAVING OF ANY STREET OR ROAD SURFACED ORIGINALLY WITH GRAVEL.
10. FOR SECTION SUBDIVISION, CORNER DOCUMENTATION, BASIS OF BEARINGS AND ADDITIONAL SURVEY INFORMATION, SEE BOOK 31 OF SURVEYS, PAGES 216-217 AND THE SURVEYS REFERENCED THEREON.
11. PARCEL E IS A PORTION OF PARCEL F AND IS SHOWN HEREON TO PROVIDE A LEGAL DESCRIPTION TO FACILITATE A FUTURE BOUNDARY LINE ADJUSTMENT.

LEGAL DESCRIPTIONS

ORIGINAL PARCELS - AFN 200603160008

PARCEL A

PARCEL A OF THAT CERTAIN SURVEY AS RECORDED MAY 11, 2006 IN BOOK 32 OF SURVEYS AT PAGES 158-160, UNDER AUDITOR'S FILE NO. 20060511 0005, RECORDS OF KITTITAS COUNTY, WASHINGTON; BEING A PORTION OF THE NORTHWEST QUARTER OF SECTION 23, TOWNSHIP 18 NORTH, RANGE 18 EAST, W.M., IN THE COUNTY OF KITTITAS, STATE OF WASHINGTON.

PARCEL B

PARCEL B OF THAT CERTAIN SURVEY AS RECORDED MAY 11, 2006 IN BOOK 32 OF SURVEYS AT PAGES 158-160, UNDER AUDITOR'S FILE NO. 20060511 0005, RECORDS OF KITTITAS COUNTY, WASHINGTON; BEING A PORTION OF THE NORTHWEST QUARTER OF SECTION 23, TOWNSHIP 18 NORTH, RANGE 18 EAST, W.M., IN THE COUNTY OF KITTITAS, STATE OF WASHINGTON.

PARCEL C

PARCEL C OF THAT CERTAIN SURVEY AS RECORDED MAY 11, 2006 IN BOOK 32 OF SURVEYS AT PAGES 158-160, UNDER AUDITOR'S FILE NO. 20060511 0005, RECORDS OF KITTITAS COUNTY, WASHINGTON; BEING A PORTION OF THE NORTHWEST QUARTER OF SECTION 23, TOWNSHIP 18 NORTH, RANGE 18 EAST, W.M., IN THE COUNTY OF KITTITAS, STATE OF WASHINGTON.

PARCEL D

PARCEL D OF THAT CERTAIN SURVEY AS RECORDED MAY 11, 2006 IN BOOK 32 OF SURVEYS AT PAGES 158-160, UNDER AUDITOR'S FILE NO. 20060511 0005, RECORDS OF KITTITAS COUNTY, WASHINGTON; BEING A PORTION OF THE NORTHWEST QUARTER OF SECTION 23, TOWNSHIP 18 NORTH, RANGE 18 EAST, W.M., IN THE COUNTY OF KITTITAS, STATE OF WASHINGTON.

PARCEL E

PARCEL E OF THAT CERTAIN SURVEY AS RECORDED MAY 11, 2006 IN BOOK 32 OF SURVEYS AT PAGES 158-160, UNDER AUDITOR'S FILE NO. 20060511 0005, RECORDS OF KITTITAS COUNTY, WASHINGTON; BEING A PORTION OF THE NORTHWEST QUARTER OF SECTION 23, TOWNSHIP 18 NORTH, RANGE 18 EAST, W.M., IN THE COUNTY OF KITTITAS, STATE OF WASHINGTON.

PARCEL F

PARCEL F OF THAT CERTAIN SURVEY AS RECORDED MAY 11, 2006 IN BOOK 32 OF SURVEYS AT PAGES 158-160, UNDER AUDITOR'S FILE NO. 20060511 0005, RECORDS OF KITTITAS COUNTY, WASHINGTON; BEING A PORTION OF THE NORTHWEST QUARTER OF SECTION 23, TOWNSHIP 18 NORTH, RANGE 18 EAST, W.M., IN THE COUNTY OF KITTITAS, STATE OF WASHINGTON.

PARCEL G

PARCEL G OF THAT CERTAIN SURVEY AS RECORDED MAY 11, 2006 IN BOOK 32 OF SURVEYS AT PAGES 158-160, UNDER AUDITOR'S FILE NO. 20060511 0005, RECORDS OF KITTITAS COUNTY, WASHINGTON; BEING A PORTION OF THE NORTHWEST QUARTER OF SECTION 23, TOWNSHIP 18 NORTH, RANGE 18 EAST, W.M., IN THE COUNTY OF KITTITAS, STATE OF WASHINGTON.

PARCEL H

PARCEL H OF THAT CERTAIN SURVEY AS RECORDED MAY 11, 2006 IN BOOK 32 OF SURVEYS AT PAGES 158-160, UNDER AUDITOR'S FILE NO. 20060511 0005, RECORDS OF KITTITAS COUNTY, WASHINGTON; BEING A PORTION OF THE NORTHWEST QUARTER OF SECTION 23, TOWNSHIP 18 NORTH, RANGE 18 EAST, W.M., IN THE COUNTY OF KITTITAS, STATE OF WASHINGTON.

EASEMENT W

EASEMENT W AS DELINEATED ON THAT CERTAIN SURVEY RECORDED MAY 11, 2006 IN BOOK 32 OF SURVEYS AT PAGES 158-160, UNDER AUDITOR'S FILE NO. 20060511 0005, RECORDS OF KITTITAS COUNTY, WASHINGTON; BEING ACROSS A PORTION OF THE NORTHWEST QUARTER OF SECTION 23, TOWNSHIP 18 NORTH, RANGE 18 EAST, W.M., IN THE COUNTY OF KITTITAS, STATE OF WASHINGTON; AFFECTING PARCELS A, B, C, D, F, G AND H OF SAID SURVEY.

AUDITOR'S CERTIFICATE

Filed for record this 11TH day of MAY,
2006, at 12:27 P.M., in Book 32 of Surveys
at page(s) 160 at the request of Cruse & Associates.

JERALD V. PETTIT BY: S. Haggerty
KITTITAS COUNTY AUDITOR

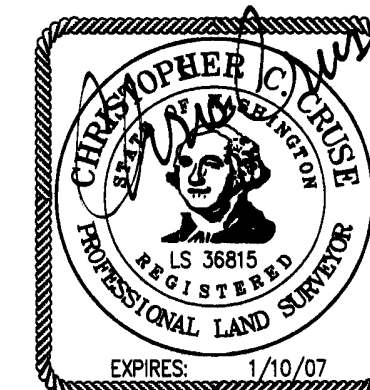

MAY 11, 2006

CRUSE & ASSOCIATES
PROFESSIONAL LAND SURVEYORS
 217 East Fourth Street P.O. Box 959
 Ellensburg, WA 98926 (509) 962-8242

DCCDLG LLC PROPERTY